

TECHNICAL SPECIFICATIONS - BAGGER:

- WEIGHT: 575 lbs [261kg]
- ELECTRICAL: 110/230 VAC; 50/60 Hz; 12/6 AMPS
- AIR: 5 CFM@80 PSI [142 litre/min] CLEAN DRY AIR

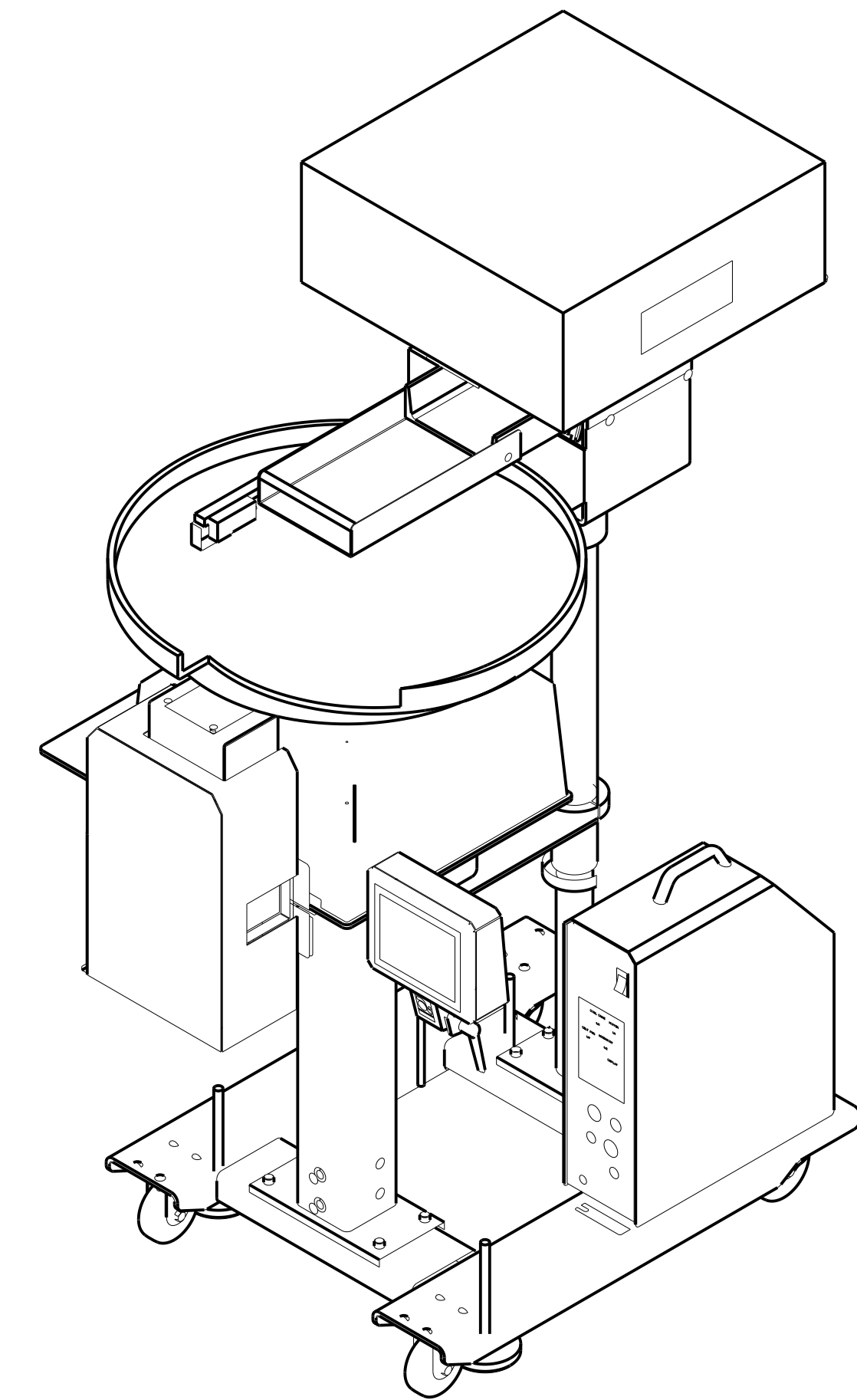

Fabricated & Documented
to be RoHS Compliant

Concept	FINISH	NONE
	MATERIAL	
	MACHINE SURFACES TO BE NO GREATER THAN 125 13.21 ✓ UNLESS OTHERWISE NOTED PART MUST BE FREE OF BURRS AND SHARP EDGES	
	TOLERANCE	INCHES mm
	1 PLACE DIMS	±.1 ±.5
	2 PLACE DIMS	±.02 ±.51
	3 PLACE DIMS	±.005 ±.10
	ANGLES	± 1/2°
NOTICE: THIS DOCUMENT CONTAINS PROPRIETARY INFORMATION AND IT SHALL NOT BE USED OR REPRODUCED OR ITS CONTENT DISCLOSED, IN WHOLE OR PART, WITHOUT THE PRIOR WRITTEN CONSENT OF AUTOMATED PACKAGING SYSTEMS INC.		
INCH [MM]	THIRD ANGLE PROJECTION	

REV	BY	DATE	ECN	DESCRIPTION
A	RCK	03/02/16	463	DRAWING FORMAT UPDATE, ADD TECHNICAL SPECIFICATIONS



DRAWING SIZE	SCALE	DRAWN BY	BOM REFERENCE NUMBER
D	1/8	RCK	
TITLE	AC220 SIDE LOAD COUNTER	DATE	03/02/16
DRAWING NO.	FP220	SHEET 1 OF 1	REV A